

VMECA VACUUM CARTRIDGE

VC252

Features and Strengths

- Two stage – VMECA mini premium cartridge
- Deep vacuum level (-94 kPa) with large vacuum flow (113NI/min)
- International patent
- Reliable performance despite inconsistent compressed air pressure



Specifications

Description	VC252
Max. Vacuum level	-94 kPa
Open Vacuum flow	113 NI/min
Max. Feed pressure	7 bar
Temperature	-20 ~ 80 °C
Material	PPS, POM, NBR, AL(Holding plug)
Weight	8.66 g

Vacuum Flow

Model	Max. vacuum (-kPa)	Feed Pressure (bar)	Vacuum flow (NI/min) at different vacuum levels (-kPa)									
			0	10	20	30	40	50	60	70	80	90
VC252	90	5	112	85	63	43	37	27	22	17	11	3.1
	94	5.5	113	91	69	48	30	26	22	17	11	2.8
	93.5	6	111	97	76.5	54	34	25	21	16	9.5	2.3

Evacuation Time

Model	Feed Pressure (bar)	Air Consumption (NI/min)	Evacuation time in sec / liter to reach different vacuum levels (-kPa)								
			10	20	30	40	50	60	70	80	90
VC252	5.0	70.5	0.039	0.15	0.27	0.49	0.60	0.94	2.09	2.82	4.83
	5.5	77.0	0.037	0.13	0.26	0.41	0.54	0.86	1.2	1.6	5.0
	6.0	83.5	0.035	0.078	0.12	0.13	0.33	0.83	1.15	1.76	5.8

Build an Ordering No.

1. Cartridge	Description	Ordering No.
	Mini premium vacuum cartridge, 2-stage	VC252
	Mini premium vacuum cartridge, 2-stage, Non-return valve	VC252-N
	Mini premium vacuum cartridge, 2-stage, Holding plug	VC252P
	Mini premium vacuum cartridge, 2-stage, Holding plug, Non-return valve	VC252P-N
	Mini premium vacuum cartridge, 2-stage, Silencer	VC252S
	Mini premium vacuum cartridge, 2-stage, Silencer, Non-return valve	VC252S-N
	Mini premium vacuum cartridge, 2-stage with vacuum filter, M16 silencer	VC252PS
	Mini premium vacuum cartridge, 2-stage with vacuum filter, M16 silencer, Non-return valve	VC252PS-N

Spare Parts – Plug

Model	Description	Weight (g)
VCP-M16-252	Holding plug	6.62
VTS-M16-252	M16 silencer	6.62

Dimension - Basic Pump

[Unit : mm]

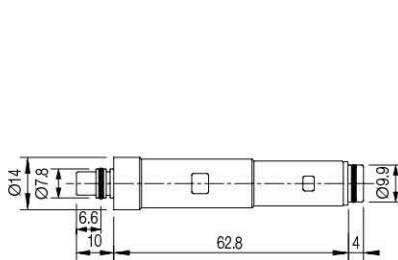

VC252

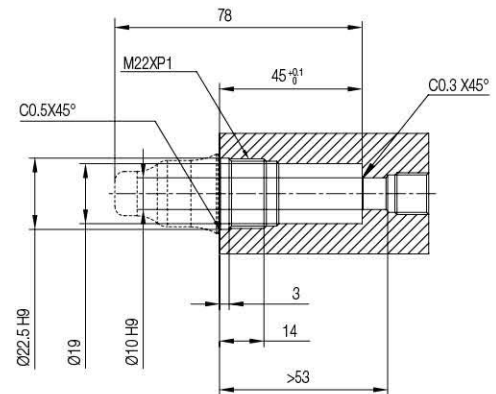

VC252P

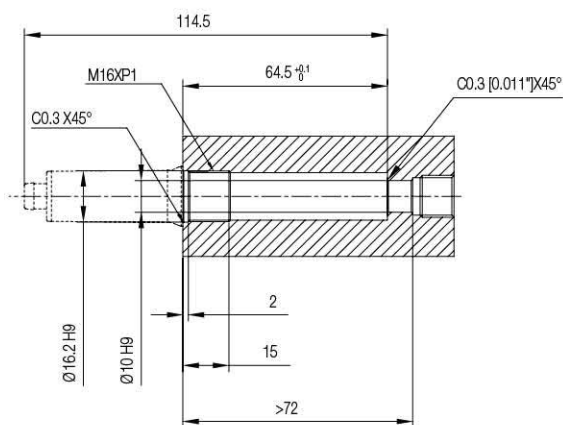

VC252FS1